

REBUILD INSTRUCTIONS

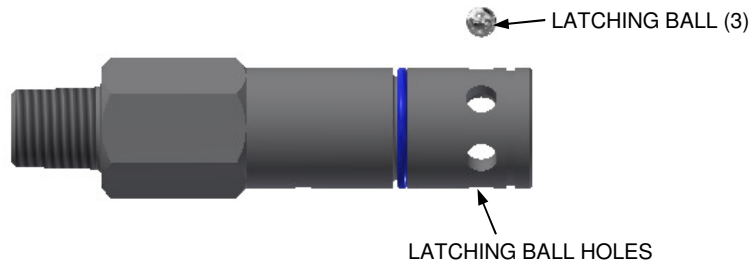

- Place a small amount of petroleum jelly into the latching ball holes in the body. This will help retain the balls while assembling the connector. Insert the larger latching balls(3) into the latching ball holes in the body.



- Lubricate the inside of sleeve(7) and slide it over the body(1) until it stops against hex on body.

- Install the retaining ring(9) into the front groove in body.

- Check connector operation and leak test.

- Discard all used components.



FasTest, Inc. Product Warranty

FasTest, Inc. warrants its products against defects of workmanship and/or material for 12 months from the date of the sale by FasTest, Inc. This warranty is void if the product is misused, tampered with or used in a manner that is not in accordance with FasTest, Inc. recommendations and/or instructions. FasTest, Inc. is not liable for consequential or other damages including, but not limited to, loss, damage, personal injury, or any other expense directly or indirectly arising from the use of or inability to use its products either separately or in combination with other products. ALL OTHER WARRANTIES EXPRESSED OR IMPLIED, WHETHER ORAL OR WRITTEN, INCLUDING BUT NOT LIMITED TO WARRANTIES OF MERCHANTABILITY OR FITNESS FOR A PARTICULAR PURPOSE ARE EXPRESSLY EXCLUDED.

Remedy under this warranty is limited to replacement of the product or an account credit in the amount of the original selling price, at the option of FasTest, Inc. All allegedly defective products must be returned prepaid transportation to FasTest, Inc. along with information describing the products performance, unless disposition in the field is authorized in writing by FasTest, Inc.

XTR Rebuild Instructions

Description: XT Connector rebuild instructions

XT Connector Exploded View

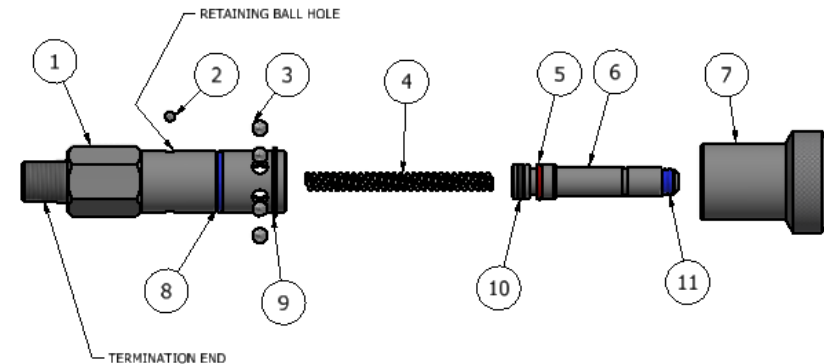

Please thoroughly read the instructions prior to rebuilding the XT Connector. If you do not understand instructions, or if components are missing, call *FasTest* before rebuilding connector.

Disassembly:

- Slide the sleeve(7) back toward the termination end to expose the retaining ring(9). Using a pick (or like tool), remove the retaining ring and discard.
- Slide the sleeve(7) off of the connector over the ball hole end.
- The latching balls(3) can now be removed. They will either fall out or they must be pushed from the inside. Remove and discard balls.

XT[®]

Roseville, MN
Ph: 1-800-444-2373
Fax: 651-645-7390
www.fastestinc.com
WP070 Rev D 10/6/2010

REBUILD INSTRUCTIONS



- Depress the piston(6) flush with body(1), then use compressed air and blow air into the smaller retaining ball hole in the body(1). The retaining balls(2) should be forced out the other, larger ball hole in the body. If they do not come out, the connector may need to be cleaned, so the balls move freely. Remove and discard balls.

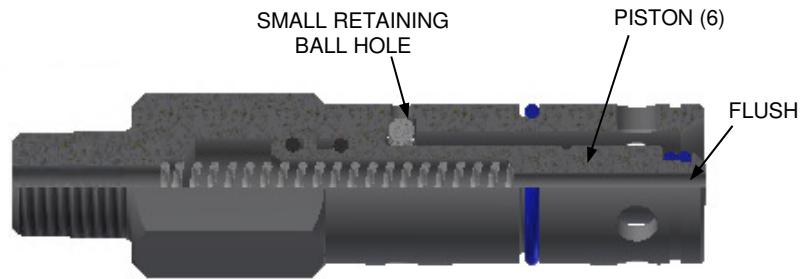

- The piston(6) should now be free. Simply pull and remove the piston(6). The internal spring(4) will be loose and can be removed.
- Remove and discard o-rings(5, 10 & 11) from the piston.
- Remove and discard the o-ring(8) from the outside of the body.

Re-Assembly:

- Make sure all components have been cleaned and are ready for assembly. Open the rebuild kit and identify the components.
- Install the smallest o-rings(11) onto the piston(6).
- Install the Teflon coated o-ring(5) into the large wider groove in the piston(6). Make sure the o-ring is located towards the front end of the piston. (As shown in step 5).
- Install o-ring(10) into the narrower groove on piston.

- Lubricate the two o-rings(5 & 10) on the large end of the piston(6) with White Petroleum Jelly. Apply lubricate so as to fill the void between the o-rings. (As shown below). **Note: Do not lubricate the small o-rings(11).**

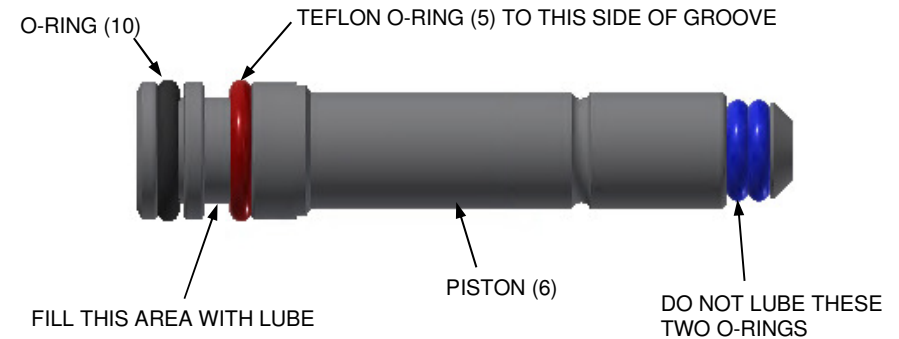

- Place the spring(4) into the piston(6) and install the assembly into the body(1).
- Compress the piston(6) into the body(1) until it stops. Install the small balls(2) through the larger retaining ball hole in the body(1).

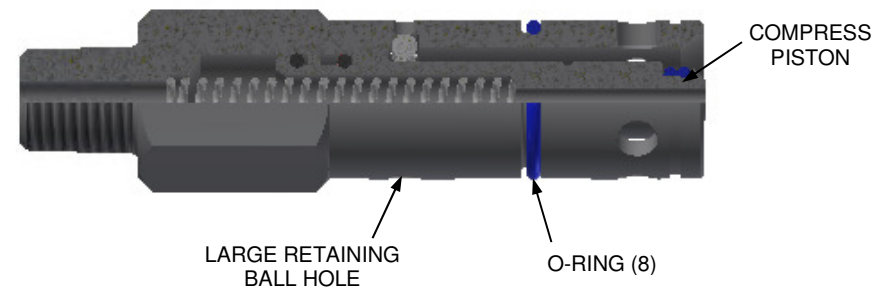

- Install the sleeve friction o-ring(8) into groove on outside of the body(1).

XT[®]

Roseville, MN
Ph: 1-800-444-2373
Fax: 651-645-7390
www.fastestinc.com
WP070 Rev D 10/6/2010