

Connector Maintenance:

- A daily, weekly and periodic inspection of the connector by competent person is recommended. User must establish a regular interval for maintenance as determined by the user media and operational environment.
- Inspection should include visual checks of the sealing area, handle wear, missing or loose components, leak tightness, ease of operation, sufficient lubrication, wear, dirt accumulation and damage.
- Establish a regular interval for lubrication. The media and environment will be determining factors in establishing this interval to prevent dryness and/or corrosion.
- Difficulty of operation after continual use indicates a need for lubrication or other maintenance.
- Use only original **FastTest** spare parts that are designed for the application and are subject to strict quality control. See Warranty.

Safety Warnings – Guidelines:

- If instructions are not completely understood by operator or components are missing, contact **FastTest** before attempting use of the connector.
- Application Safety: All **FastTest** products have been designed with safety in mind, however, it is the responsibility of the products users to design each process in such a way to avoid mishaps that can cause physical hazard or property loss. Secondary restraints such as safety chains, shields, cages or fixtures are all good choices depending on the application. **FastTest** can recommend or assist you in clarifying potential hazards of your application.
- **FastTest ZGN** Connectors are not internally valved, and will not prevent loss of media when disconnected. Do not attempt to disconnect unless safe conditions are met.
- **FastTest ZGN** Connectors must only be used with test pieces of a specific size as indicated by the part number. Improper use could cause separation of the connector from the test piece resulting in physical harm or damage.

FastTest, Inc. Product Warranty

FasTest, Inc. warrants its products against defects of workmanship and/or material for 1 year from the date of the sale by FasTest, Inc. This warranty is void if the product is misused, tampered with or used in a manner that is not in accordance with FasTest, Inc. recommendations and/or instructions. FasTest, Inc. is not liable for consequential or other damages including, but not limited to, loss, damage, personal injury, or any other expense directly or indirectly arising from the use of or inability to use its products either separately or in combination with other products. ALL OTHER WARRANTIES EXPRESSED OR IMPLIED, WHETHER ORAL OR WRITTEN, INCLUDING BUT NOT LIMITED TO WARRANTIES OR MERCHANTABILITY OR FITNESS FOR A PARTICULAR PURPOSE ARE EXPRESSLY EXCLUDED.

Remedy under this warranty is limited to replacement of the product or an account credit in the amount of the original selling price, at the option on FasTest, Inc. All allegedly defective products must be returned prepaid transportation to FasTest, Inc. along with information describing the products performance, unless disposition in the field is authorized in writing by FasTest, Inc.

ZGNP Pneumatic Activated Connectors

Description: ZGNP Series Connectors Grip and Seal Female Threaded Ports.

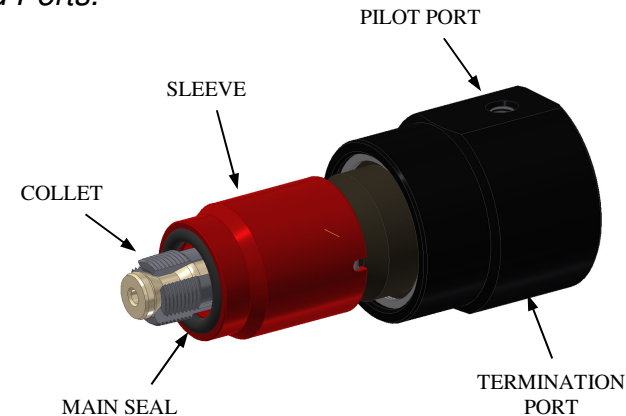

ZGN Connectors provide a reliable leak-tight connection that grips female threads and seals on part face. Simply insert male end of connector into threaded port, vent pilot pressure and apply termination pressure.

Please thoroughly read and understand these operating instructions prior to operating the connector. The use of pressurized media for sealing and testing requires a thorough understanding of the **FastTest ZGN** Operating Instructions.

- Installation
- Operation
- Connector Maintenance
- Safety Warnings – Guidelines

OPERATING INSTRUCTIONS/MAIN SEAL REPLACEMENT

Installation:

Connect supply lines to the pilot and termination ports.

ZGNP1 & 2 Pilot port is 10-32 UNF x 1/8 NPT Termination port.

ZGNP3 & 4 Pilot port is 1/8 NPT x 1/4 NPT Termination port.

Mounting holes are available on the pneumatic version for automation applications.

ZGNP1 & 2 mounting hole spacing = .875"

ZGNP3 & 4 mounting hole spacing = 1.125"

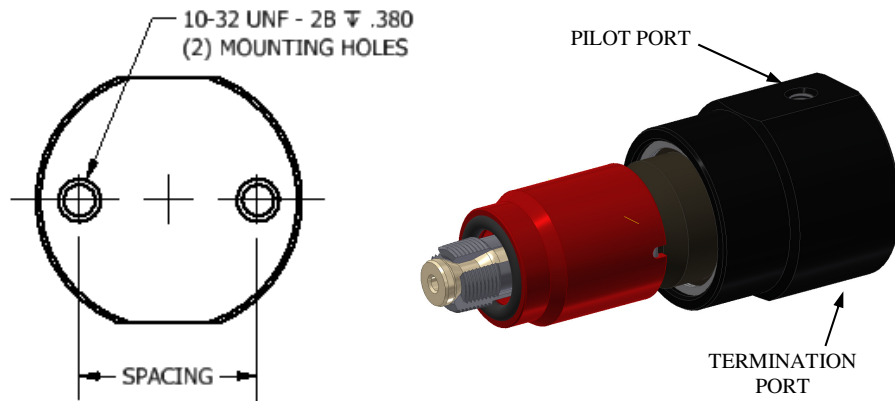

Operation:

Connecting Action:

1. Apply pressure to the pilot port, this will move shaft forward and allow collets to relax. The relaxed position allows connector to be inserted into female threaded port.

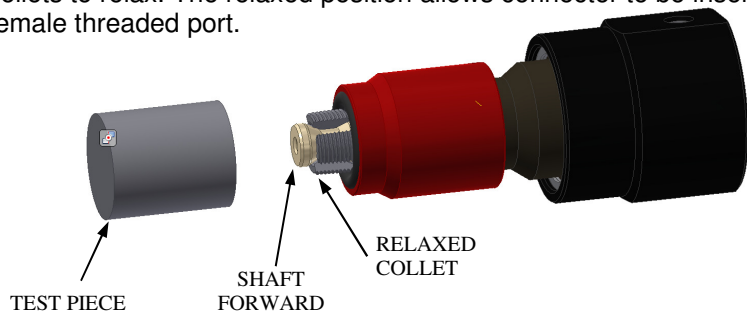

2. Insert connector into threaded port.
3. Insert until main seal contacts port face plus another .06-.11 of sleeve compression travel. This will ensure that seal is in contact with part face.

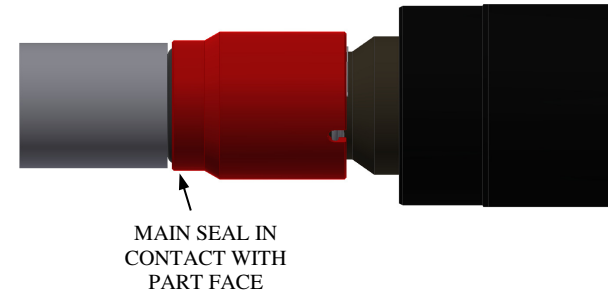

4. Release/vent the pilot port. This will drive/grip the collet into the test piece threads. As the collet grips the test piece the seal contact increases.
5. Connector is now ready to be pressurized through the termination port.
 - **NOTE: DO NOT APPLY TERMINATION PRESSURE UNTIL PILOT PORT HAS BEEN RELEASED/VENTED!**
6. Perform test.
7. Apply pressure to pilot port to relax the collet from gripping the test piece and remove test piece from connector.
 - **CAUTION NOTES:**
 - CAUTION: The maximum rated pressure is stamped on the connector sleeve. Before using, verify that this pressure rating is within your working pressures.
 - **WARNING: Tug on the connector to assure proper engagement and gripping before introduction of pressurized media.**
 - **DO NOT** force connector onto test part when connecting. Forcing the connector will result in poor sealing and possible leakage.
 - **DO NOT** spin test piece on seal once lever has been rotated 90° degrees.

Disconnecting Action:

1. When test is complete deactivate/relieve test/termination pressure.
2. Apply pressure to the pilot port to relax the collet from gripping the test piece and remove test piece from connector.

MAIN SEAL REPLACEMENT:

1. Main seal removal and installation needs to be done with pressure applied to the pilot port. This allows easy removal and installation of o-ring with relaxed collets.
2. Using a small flat screwdriver or sharp pick tool, remove o-ring from sleeve groove. USE CAUTION NOT TO SCRATCH GROOVE SURFACES.
3. No tools required to install new main seal o-ring. Roll o-ring over collet and push o-ring into groove on nose of the sleeve.

