



TOOLS & SYSTEMS

FASTEST[®]



**SAFE.
RELIABLE.
FAST.**

HVAC-R
SEALING CONNECTION TOOLS

2024 HVAC-R PRODUCT GUIDE

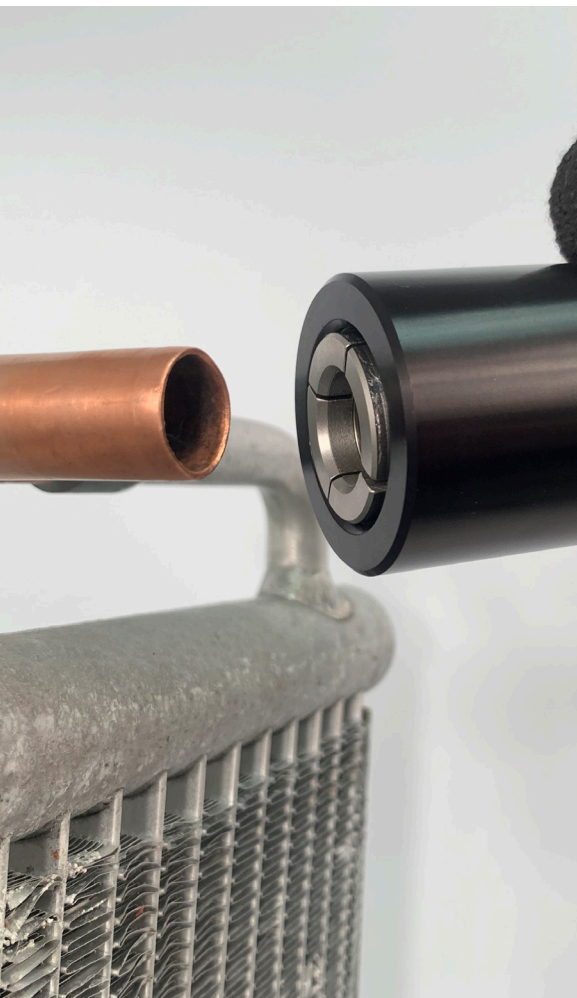
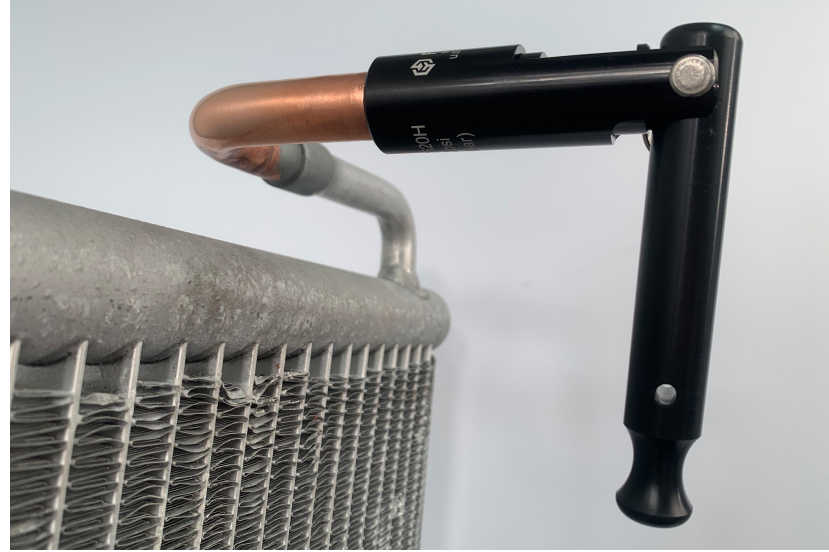



FASTEST®

SAFE, RELIABLE, FAST SEALING CONNECTIONS

Enhance Test Safety | Drive Continuous Improvement | Ensure Product Quality

FasTest® is a dedicated manufacturer of advanced engineered sealing connection tools and process valves that provide improved safety and efficiency - lowering operating costs.

CoreMax® System - p.3

An access valve with matched tooling designed specifically to reduce evacuation times, improve quality, and provide greater throughput, with less maintenance.

Connection Tools - p.9

FasTest® connection tools have become the standard for safe and reliable connection requirements. Ergonomic designs and easy maintenance makes FasTest® the industry preferred source.

Applications

- SPLIT SYSTEMS
- PACKAGE UNITS
- COILS
- COMPRESSORS
- ICE MACHINES
- AND MORE



APPLICATION EXPERTS

We work with you to provide the best solution for your application.



QUALITY

ISO 9001 Certified; Robust tools improve the quality of your product.



BREADTH OF OFFERING

Extensive standard and Custom Engineered Solutions.



INTELLIGENT TOOLS

Industry 4.0 sensing & data generating tools



GLOBAL SUPPORT

Global distribution coverage for local and responsive distribution support.

COREMAX[®] SYSTEM

A Complete Solution for Efficient Refrigerant Processing & Leak Testing of HVAC Systems

The **CoreMax[®]** System eliminates process tubes and Schrader[®] valves for faster evacuation times, improved quality, greater throughput, and less maintenance costs.

Evacuation Time of known Volume

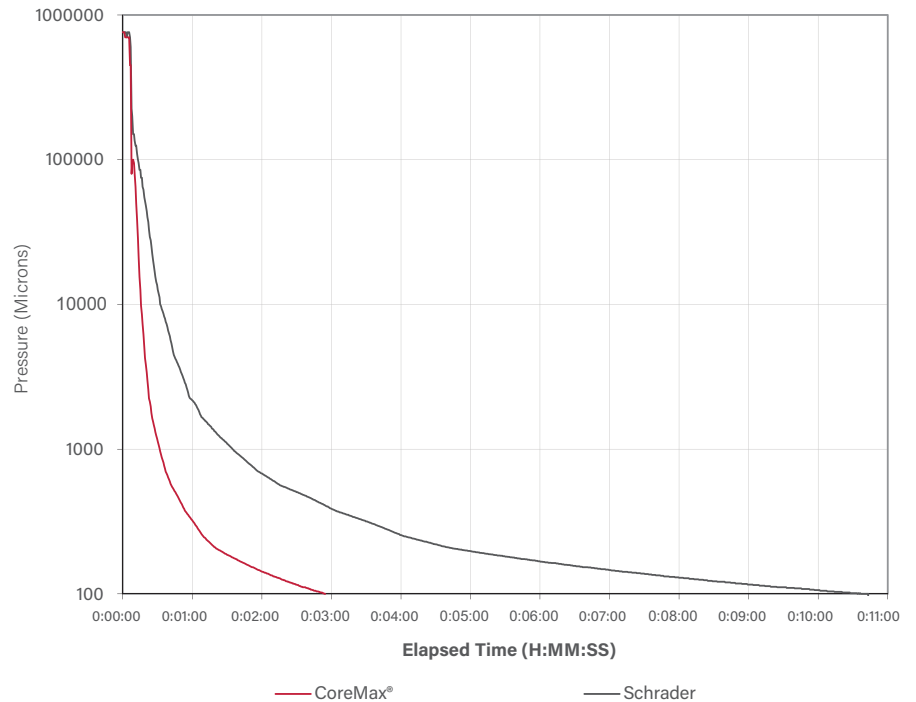

COREMAX BENEFITS

- 1** An entire processing solution for HVAC including tools that has over 20 million units installed in 8 countries and 3 continents
- 2** Eliminates process tubes and Schrader[®] fittings
- 3** Provides increased efficiencies and throughput due to increased flow, resulting in reduced costs
- 4** Provides the largest vacuum conductance in the industry
- 5** Proven family of tools specifically designed for manufacturing and service that reduce plant tooling costs by up to 15%
- 6** Ergonomic tools reduce operator fatigue and overall manufacturing costs
- 7** Robust sealing solution designed specifically for the HVAC industry for sealing longevity and reduced warranty costs
- 8** Reduce rework from leaking Schrader valves by up to 99%
- 9** Conforms to the 7/16-20 45° flare interchangeable standard commonly used for access valves making it field service friendly. Completely compatible with standard refrigeration tooling and connections

- ✓ SPLIT SYSTEMS
- ✓ PACKAGE UNITS
- ✓ COILS
- ✓ COMPRESSORS
- ✓ ICE MACHINES
- AND MORE



MANUFACTURING PROCESSING TOOLS

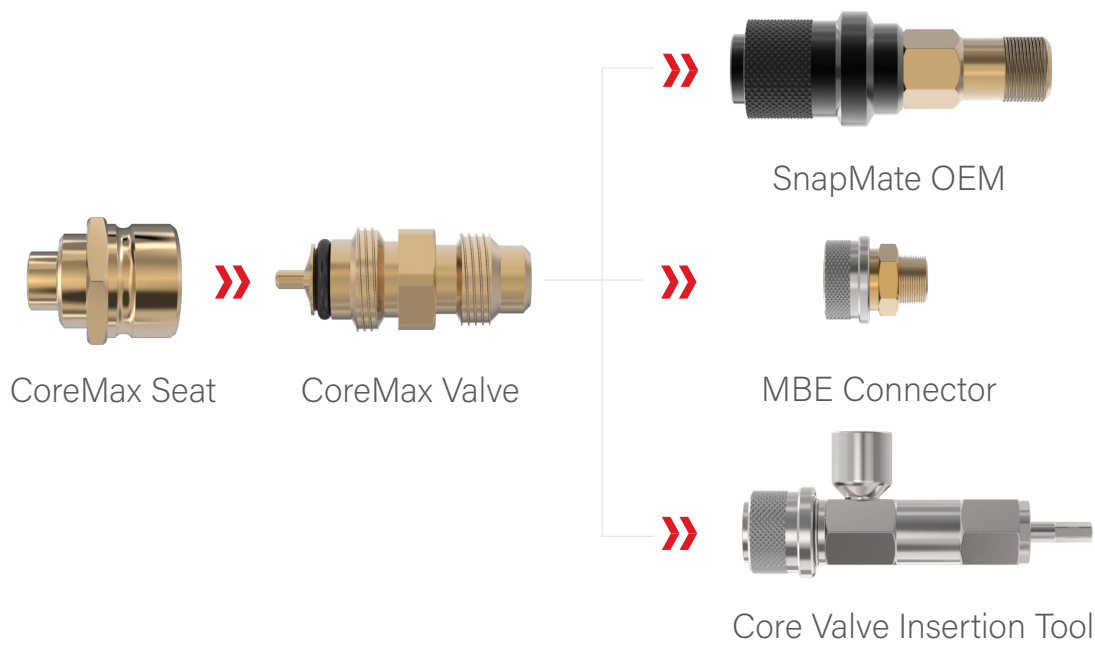

FIELD / MANUFACTURING SERVICE TOOLS

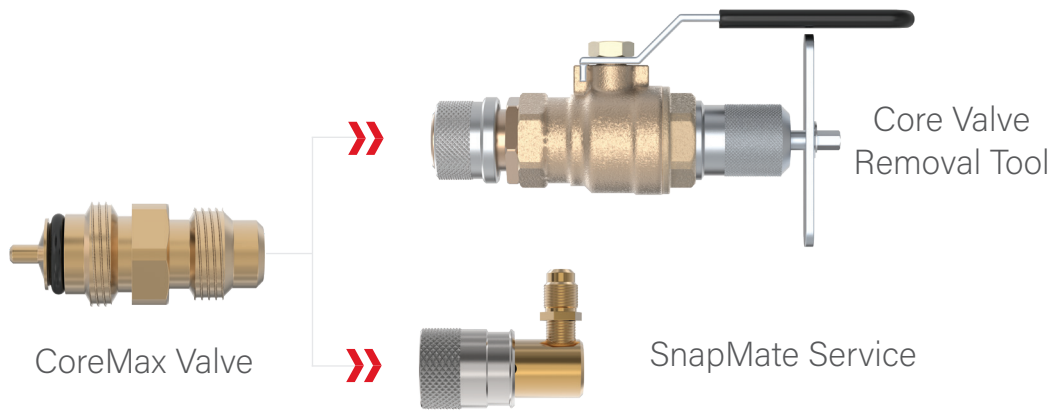

CoreMax® / Valve & Seat Styles

CoreMax® Valve mates with the CoreMax® Seat to form the complete access valve.

MATES WITH COREMAX® SEAT FOR COMPLETE ACCESS VALVE:

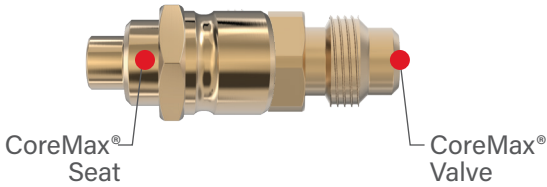

SPECIFICATIONS

Pressure Rating	Operating Temperatures	Materials of Construction
Vacuum to 700 psi (48.2 bar)	-40°F to +250°F (-40°C to +121°C)	Stainless Steel, Neoprene®

COREMAX® SEATS

For complete access valve.



- 1 Specifically designed for refrigeration applications maximizing flow and robust sealing technology.
- 2 The CoreMax® core utilizes one elastomeric seal to seal both the valve as well as the joint between the core and the seat. There is a metal to metal seal between the core and seat to ensure a complete seal.
- 3 The valve core pin position is manufactured to exact tolerances for constant sealing and maximum valve opening for the highest flow available. The Valve conforms to ARI standard 720 for pin height
- 4 The CoreMax® valve has a 7/16-20 45° flare which is the industry standard for access valves, so all standard service tools can be used.

- Manufactured to exacting tolerances, the seat is designed to mate with the CoreMax® valve core and form the sealing capability
- Designed with gripping and sealing surfaces to work with the CoreMax® system tools Internally valved
- Many options are available to fit any user system

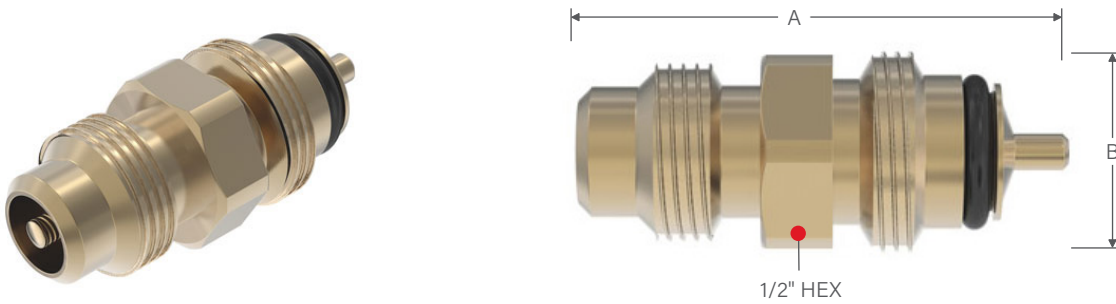

Ordering Information	Dimensions	
Part Number	A	B
CoreMax® Valve Mates with CoreMax® Seat for Complete Access Valve		
SCCA07H	1.00 (25.4)	1.00 (25.4)

Dimensions: inch (mm)



Ordering Information			Dimensions				Installed Length*
Style	Size	Part Number	A	B	C	D	

CoreMax® Seats | Multiple Styles for User's Application

Stub Tube	1/4	SCH0730A01	1.00 (25.4)	0.21 (5.3)	0.22 (5.6)	0.31 (7.9)	1.26 (32.0)
	3/8	SCH0730A03			0.32 (8.1)	0.43 (10.9)	
Saddle Mount	3/8 - 0.38 Hole	SCH0730B02	0.92 (23.4)	0.13 (3.3)	0.28 (.71)	0.37 (9.4)	
	1/4 - 0.22 Hole	SCH0730B03			0.07 (1.8)	0.22 (5.6)	
	1/4 - 0.25 Hole	SCH0730B04			0.13 (3.3)	0.18 (4.6)	0.25 (6.4)
Panel Mount	1/4	SCH0730C03	1.29 (32.8)	0.67 (17.0)	0.22 (5.6)	0.35 (8.9)	1.33 (33.8)
	3/8	SCH0730C04			0.35 (8.9)	0.44 (11.2)	
NPT	1/4	SCH0730E01	1.15 (29.2)	0.54 (13.7)	0.31 (7.9)	-----	

Dimensions: inch (mm)

* Installed length is CoreMax® Valve and CoreMax® Seat torqued together.

MANUFACTURING PROCESSING TOOLS

SnapMate OEM

PN: SCP062H



Pressure Rating	Termination	Materials of Construction
10 millitorr (micron) vacuum to 700 psi (48.2)	3/8 MNPT	Stainless Steel, Brass, Neoprene

- Internal valve opens automatically upon connection and closes upon disconnection.
- Can be actuated under full pressure due to its mechanical advantage design and used in both vacuum and pressure applications
- Grips behind threads to eliminate potential thread damage with matched flow through the CoreMax® valve for efficient processing.
- Easy sleeve action is ergonomic and eliminates repetitive twisting and turning - Push to connect, pull to release

APPLICATION

Use at burst, evacuation, charge and rework stations for generalized processing. Use at every station to connect to CoreMax® Valve.

MBE

PN: SCM062W



Pressure Rating	Termination	Materials of Construction
10 millitorr (micron) vacuum to 700 psi (48.2)	3/8 MNPT	Stainless Steel, Brass, Neoprene®

- Pressure interlocks prevent sleeve actuation under pressure
- High flow connection tool with no flow restriction. Used to maximize flow through the seat
- Grips over the seat so it can be used with or without the CoreMax® valve
- Easy sleeve action is ergonomic and eliminates repetitive twisting and turning

APPLICATION

Use at burst, leak test stations with or without CoreMax® valve. Use at evacuation station with CoreMax® Valve installed.

Core Valve Insertion Tool

PN: SCFT10



Pressure Rating	Termination	Materials of Construction
10 millitorr (micron) vacuum to 700 psi (48.2)	3/8 FNPT	Stainless Steel, Neoprene®

- Pressure interlocks prevent sleeve actuation under pressure
- Grips over valve seat to allow for maximum evacuation through the seat prior to inserting CoreMax core valve
- Available load tool for easy core insertion into the tool. Fastest PN: SCFTL1010
- Easy sleeve action is ergonomic and eliminates repetitive twisting and turning

APPLICATION

Use at evacuation stations to maximize flow for extreme volumes to achieve maximum throughput. Insertion of valve core prior to further processing.

Installation Oiler

PN: SCL321



Materials of Construction
HDPE, Brass

- Custom nest to oil CoreMax core with overflow containment
- Reservoir has check valve to keep small amount of oil available for lubrication
- Oil containment keeps contaminants away and minimizes oil exposure to atmosphere
- Pump to fill reservoir

APPLICATION

Use to oil the CoreMax® Valve core prior to insertion and torque into valve seat.

FIELD / MANUFACTURING SERVICE TOOLS

Core Valve Removal Tool

PN: SCFT20A

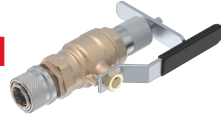

Pressure Rating	Termination	Materials of Construction
10 millitorr (micron) vacuum to 750 psi (51.7)	N/A	Stainless Steel, Brass, Neoprene®

- Pressure interlocks prevent sleeve actuation under pressure
- Grips over the valve seat to allow for CoreMax® Valve core removal and replacement without reclaiming the system
- Ball valve design to shut off system pressure
- Easy sleeve action is ergonomic and eliminates repetitive twisting and turning. Thread out/in core, rotate ball valve and replace.

APPLICATION

Use to remove and replace CoreMax® Valve core in charged units.

SnapMate Service

PN: SCTA07H



Pressure Rating	Termination	Materials of Construction
Vacuum to 625 psi (43.1)	7/16 45° Flare	Stainless Steel, Brass, Neoprene®

- Internal valve opens automatically upon connection and closes upon disconnection and has internal actuation pin to open CoreMax® Valve
- Threaded collets grip in the threads of any 7/16-20 45° flare access valve (CoreMax and Schrader)
- Can be actuated and removed under standard system pressure
- Easy sleeve action is ergonomic and eliminates repetitive twisting and turning - Push to connect, pull to release

APPLICATION

Use by HVAC service technicians for field service.

Electric Torque Wrench

PN: SCFTP0502



Materials of Construction
IR Electronic Tool

- Pre-programmed to CoreMax® specifications of <200RPM and 8ft-lbs torque
- Hold and drive feature supports the seat so no stress is incurred on the system or operator
- 20 volt battery powered tool. Can be programmed to tailor specific needs
- Pull trigger to run tool to proper torque

APPLICATION

Use to proper torque the CoreMax® Valve core into the core seat.

Manual Torque Wrench

PN: SCFTM01



Materials of Construction
Stainless Steel

- Break away torque wrench pre-set to proper torque of 8ft-lbs.
- Manually twist wrench to pre-set torque

APPLICATION

Use to proper torque the CoreMax® valve core into the core seat.

CONNECTION TOOLS »

FasTest® sealing tools have become the standard for safe and reliable connection requirements. Ergonomic designs and easy maintenance makes FasTest® the industry preferred connector source.



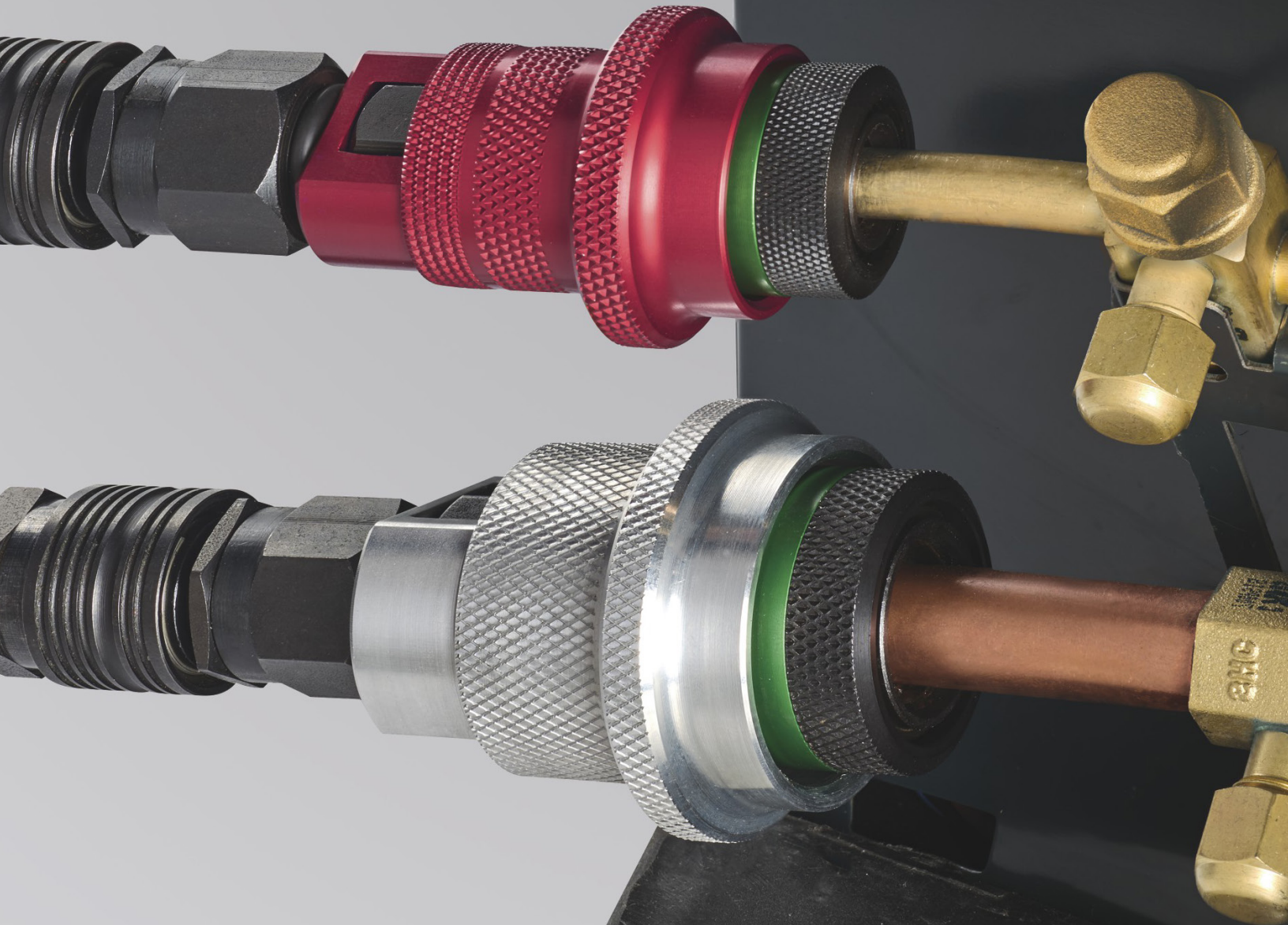

1 Identify "Connects to" or Tube/Thread type for application

2 Select tool(s) that fit size requirements



DESIGNED FOR	HVAC-R Tubes / Fittings / Access Ports				
PRODUCT SERIES	XT (p.13)	ST (p.15)	RQD (p.17)	SNAPMATE (p.19)	MBE / MRE (p.21)
Pressure rating	Vacuum 10 mtorr (micron) to 625 psi (43.1 bar)	Vacuum 10 mtorr (micron) to 1,000 psi (68.9 bar)	Vacuum 10 mtorr (micron) to 750 psi (51.7 bar)	Vacuum 10 mtorr (micron) to 625 psi (43.1 bar)	Vacuum 10 mtorr (micron) to 625 psi (51.7 bar)
Connects to	Expanded Tubes	Straight Tubes	Hansen® and PCU® Male Fittings	CoreMax® /Schrader® Access Ports	Expanded Tubes
Sealing range	5/16", 3/8", 1/2" 5/8", 3/4", 7/8"	1/4", 5/16", 3/8"	1/4", 5/16", 3/8"	7/16-20 flare	1/4" to 1 1/8"
Application type	Manual	Manual	Manual	Manual	Manual
Actuation method	Sleve	Sleeve	Sleeve / Lever	Sleeve	Sleeve
Grip method	Ball Latch	Thread Collets	Ball Latch	Thread Collets	Ball / Ring Latch



DESIGNED FOR	Gas Burner Testing	
PRODUCT SERIES	GZNV (p.29)	G60V (p.30)
Pressure rating	Vacuum to 5 psi (0.4 bar)	Vacuum to 30 psi (2.1 bar)
Connects to	Natural Gas and Propane Regulators	Natural Gas and Propane Regulator Extension Pipes
Sealing range	3/8, 1/2, 3/4 Female NPT/BSPP (G)	3/8, 1/2, 3/4 Male NPT/BSPP (G)
Application type	Manual	Manual
Actuation method	Sleve	Sleeve
Grip method	Seal Friction	Thread Collets

»» INDUSTRY LEADING RESPONSIVENESS

- Majority of products ship within 2 days.
- Custom Engineered Solutions, including design, ship in weeks vs. months

AT FASTEST WE TAKE PRIDE IN BEING RESPONSIVE TO ALL OUR CUSTOMER'S NEEDS, INCLUDING PRODUCT AVAILABILITY.

3 Verify operating/test pressure meets requirements

4 Select actuation method - lever/sleeve for manual, pneumatic for automation

5 Identify desired ICON™ features



DESIGNED FOR		HVAC-R Tubes		Internal Connections to Tubes / Threads			External Connections to Tubes / Threads	
PRODUCT SERIES		JNL (p.23)	JXL (p.27)	FI (p.31)	MIT (p.33)	FN (p.35)	FE (p.32)	MET (p.34)
Pressure rating		Vacuum 10 mtorr (micron) to 1,000 psi (68.9 bar)	Vacuum 10 mtorr (micron) to 1,000 psi (68.9 bar)	Vacuum 10 to 120 psi (8.1 bar)	Vacuum to 10,000 psi (689.5 bar)	Vacuum to 5,000 psi (344.7 bar)	Vacuum to 500 psi (34.5 bar)	Vacuum to 10,000 psi (689.5 bar)
Actuation method		Lever	Lever	Pneumatic	Manual Twist	Squeeze Lever	Pneumatic	Manual Twist
Grip method		Grip Collets	Grip Collets	Fixturing / Seal Friction	Continuous Thread	Thread Collets	Fixturing / Seal Friction	Continuous Thread
ICON™ Technology				SURE SEAL™ SEAL LIFE™		SURE SEAL™	SURE SEAL™ SEAL LIFE™	
TUBES	STRAIGHT	0.375" to 1.625" 9.53mm to 41.275mm	0.25" to 0.875" 6.3mm to 22.2mm	0.310" to 3.005" 7.87mm to 76.33mm	N/A	N/A	0.030" to 5.040" 0.76mm to 128.02mm	N/A
	SWAGED							
	EXPANDED							
	FLARED							
	BEADED	N/A	N/A	0.310" to 3.005" 7.87mm to 76.33mm	N/A	N/A	0.030" to 5.040" 0.76mm to 128.02mm	N/A
	BARBED							
	FORMED							
THREADS	NPT	N/A	N/A	1/8 to 2 1/2	1/8 to 4	1/8 to 3/4	1/8 to 2 1/2	1/8 to 3
	BSPP/BSPT	N/A	N/A	1/8 to 2 1/2	1/8 to 1	1/8 to 3/4	1/8 to 2 1/2	1/8 to 1
	JIC 37° FLARE	N/A	N/A	N/A	7/16-20 to 1 5/16-12 (-4 to -16)	N/A	7/16-20 to 1 5/16-12 (-4 to -16)	7/16-20 to 2 1/2-12 (-4 to -32)
	45° FLARE	N/A	N/A	N/A	N/A	N/A	7/16-20 to 1 3/8-12 (-4 to -16)	7/16-20 to 1 1/16-14 (-4 to -12)
	METRIC	N/A	N/A	M10 to M60	M10 to M22	M10 to M22	M10 to M33	CONSULT FACTORY



DON'T SEE A SOLUTION FOR YOUR APPLICATION? Submit a custom application form and drawing to fastsales@fastestinc.com or to your local distributor.

XT / HVAC-R EXTERNAL SEALING CONNECTION TOOL

Sleeve actuated ball grip connection tool for expanded refrigeration tubes.

CONNECTS TO:

Expanded



Base connector now made of stainless steel

SPECIFICATIONS

Pressure Rating	Operating Temperatures	Connection Profile
10 mtorr (micron) to 625 psi (43 bar)	-40°F to +250°F (-40°C to +121°C)	Expanded Tubes
Housing Material		
Connector - Stainless Steel SurConnect™ - Aluminum		
Termination Profile	Seal Material*	
1/4 NPT	Neoprene®	

* More seal material types available, consult factory.

- 1 Sleeve locks under pressure to prevent accidental disconnection
- 2 Instant connection for copper and aluminum flared tubes commonly used in refrigeration
- 3 Connects to a broad range of flared ends including rough cut ends
- 4 Deep vacuum capabilities down to 10 millitorr (micron)
- 5 Quick and easy seal replacement to minimize down time, maintenance, and tool inventory

ACTUATION METHOD

Manual Sleeve: Easy, ergonomic sleeve action eliminates repetitive twisting and turning - push to connect, pull to release

ICON™ TECHNOLOGY

Consult Factory

ACCESSORIES

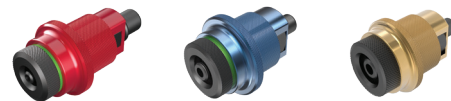

The SurConnect™ Advantage

- Green ring indicates a secure connection, improving safety by preventing accidental disconnects.
- Easily installed on existing XT Connectors or available fully assembled.
- Aluminum light weight.
- Color coded by size for easy recognition.

XT / HVAC-R EXTERNAL SEALING CONNECTION TOOL

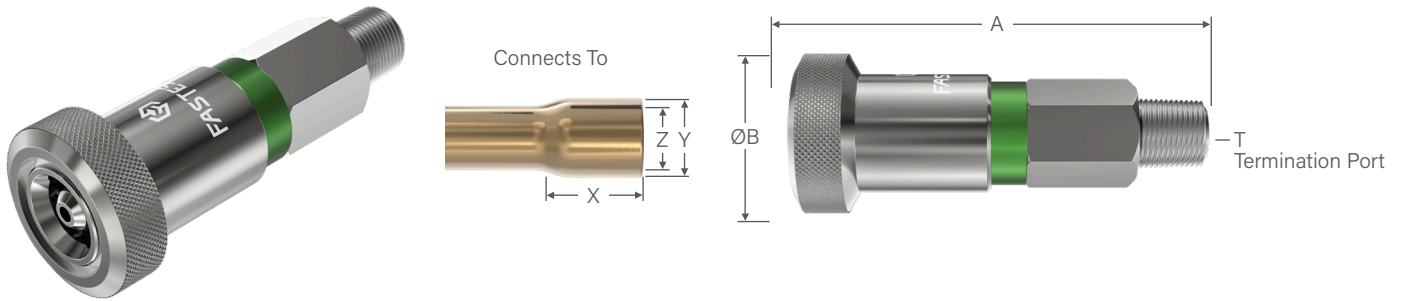

Ordering Information							Dimensions			
Connects To				Part Number	Replacement Seals Bulk Pack (5)	Rebuild Kit	A	B	T	Flow Ø
Tube Size	Flare Length (Dim X)	Flare OD (Dim Y)	Flare ID (Dim Z)							

XT | Sleeve Actuated Connectors for Expanded Tubes

5/16	0.30 to 1.00 (7.6 to 25.4)	0.44 (11.2)	0.31 (7.9)	XT05042	XTB05	XTR05	3.23 (82.0)	1.19 (30.2)	1/4 NPT	.062 (1.6)
3/8		0.50 (12.7)	0.37 (9.4)	XT06042	XTB06	XTR06		1.25 (31.8)		0.12 (3.1)
1/2		0.63 (15.9)	0.49 (12.4)	XT08042	XTB08	XTR08		1.37 (34.8)		0.22 (5.6)
5/8		0.73 (18.5)	0.62 (15.7)	XT10042	XTB10	XTR10		1.50 (38.1)		0.25 (6.4)
3/4	0.37 to 1.00 (9.4 to 25.4)	0.86 (21.8)	0.74 (18.8)	XT12042	XTB12	XTR12	3.33 (84.6)	1.62 (41.2)		0.27 (6.9)
7/8		0.99 (25.1)	0.87 (22.1)	XT14042	XTB14	XTR14		1.72 (43.7)		0.28 (7.1)

Dimensions: inch (mm)

(i) NOTE: Not recommended for water dunk applications.

Ordering Information				
Connects To	SurConnect™ Kit Part Number	XT with SurConnect™	XT with SurConnect™ & Process Tip	Tip

XT WITH SURCONNECT™ | Sleeve Actuated Connectors for Expanded Tubes with Additional Safety Feature

3/8	XT06SHR3	XT06042SHR3	XT06042SHR3H4	1/4 Hansen®
			XT06042SHR3P4	1/4 PCU*
			XT06042SHR3H6	3/8 Hansen®
			XT06042SHR3P6	3/8 PCU*
3/4	XT12SHR2	XT12042SHR2	XT12042SHR2H4	1/4 Hansen®
			XT12042SHR2P4	1/4 PCU*
			XT12042SHR2H6	3/8 Hansen®
			XT12042SHR2P6	3/8 PCU*
7/8	XT14SHR1	XT14042SHR1	XT14042SHR1H4	1/4 Hansen®
			XT14042SHR1P4	1/4 PCU*
			XT14042SHR1H6	3/8 Hansen®
			XT14042SHR1P6	3/8 PCU*

(i) NOTE: Not recommended for water dunk applications.



DON'T SEE A SOLUTION FOR YOUR APPLICATION? Submit a custom application form and drawing to fastsales@fastestinc.com or to your local distributor.

ST / HVAC-R EXTERNAL SEALING CONNECTION TOOL

Sleeve actuated grip and seal connection tool for straight tubes in refrigeration.

CONNECTS TO:

Straight



Now made of stainless steel

SPECIFICATIONS

Pressure Rating	Operating Temperatures	Materials of Construction
10 mtorr (micron) to 1000 psi (69 bar)	-40°F to +250°F (-40°C to +121°C)	Stainless Steel
Termination Port		Seal Material*
1/4 NPT		Neoprene®

* Additional seal material types available, consult factory.

ACTUATION METHOD

Manual Sleeve: Easy sleeve action is ergonomic and eliminates repetitive twisting and turning. Pull to connect, push to release.

ICON™ TECHNOLOGY

Consult Factory

ACCESSORIES

Visit fastestinc.com

- 1 Pressure assisted sealing eliminates leaks and resists movement under pressure
- 2 Instant connection for copper, steel, and aluminum tubes commonly used in refrigeration
- 3 Designed specifically for the demanding requirements of the refrigeration industry
- 4 Deep vacuum capabilities down to 10millitorr (micron)
- 5 Quick and easy seal replacement to minimize down time, maintenance, and tool inventory

ST / HVAC-R EXTERNAL SEALING CONNECTION TOOL

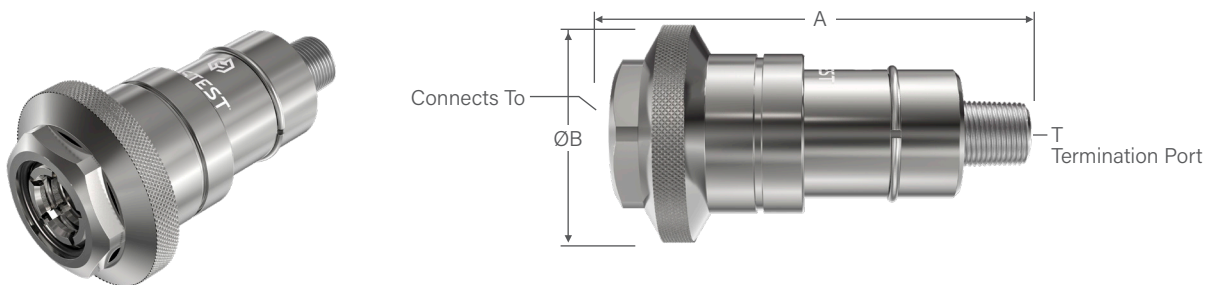

Ordering Information				Dimensions			
Connects To +0.015/-0.010	Part Number	Replacement Seals Bulk Pack (5)	Rebuild Kit*	A	B	T	Insertion Depth
0.250 (6.4)	ST04042	STB04	STC04	2.75 (69.9)	1.14 (29.0)	1/4 NPT	0.62 (15.7)
0.312 (7.9)	ST05042	STB05	STC04		1.19 (30.2)		
0.375 (9.5)	ST06042	STB06	STC04	3.23 (82.0)	1.50 (38.1)		0.75 (19.1)

Dimensions: inch (mm)

*Includes complete collet set.

Additional sizes available, contact factory.



RQD / HVAC-R EXTERNAL SEALING CONNECTION TOOL

External sealing connection tool for attachment to Hansen® and PCU® tips under pressure.

CONNECTS TO:

Hansen® Tips PCU® Tips



- 1 Sleeve lock connection prior to pressure engagement minimizes force to connect through handle activation
- 2 Connects and vents even under pressure using lever handle to keep refrigerant away from the operator
- 3 Internal HTPE seal to keep refrigerant from exhaling back onto operator
- 4 Internal poppet style seal for dry refrigerant operation
- 5 Minimal maintenance required



SPECIFICATIONS

Pressure Rating	Operating Temperatures	Materials of Construction
Vacuum to 750 psi (52 bar)	-40°F to +250°F (-40°C to +121°C)	Black Oxide Steel
Termination Port		Seal Material*
1/4 or 3/8 NPT		Neoprene®

* Additional seal material types available, consult factory.

- i Designed for ISO 7241-1 Series B coupling "Tips"
- i RQD can mate with, but not limited to, the following brands: Parker® 60, PCU® 250 & 410, Hansen® HK, SABE® IB Series (China), AeroQuip® FD45, Faster® HNV Series, Snap-Tite® 72 series, Stucchi® IRB, Perfecting® H Series, Safeway® S10 Series, Tomco® H Series, Cejn® X75, Foste®r HX-S, and Nitto® 250.

ACTUATION METHOD

Sleeve / Lever Handle: Easy sleeve connection is ergonomic and eliminates repetitive twisting and turning, cam over lever handle opens poppets under pressure

ICON™ TECHNOLOGY

Consult Factory

ACCESSORIES

Visit fastestinc.com

RQD / HVAC-R EXTERNAL SEALING CONNECTION TOOL



Ordering Information				Dimensions			
Connects To	Part Number	Replacement Seals Bulk Pack (5)	Rebuild Kit	A	B	C	D

RQD | Lever Action Style for PCU* Tips

1/4 PCU*— Model 64 Tip	KA04PA	KSA04	KR04A	1.75 (44.5)	4.39 (111.5)	7.00 (177.8)	1/4 NPT
1/4 PCU*— Model 61 Tip	KA04PB	KSM04	KR04				3/8 NPT
3/8 PCU*— Model 78 Tip	KA06PA	KSM06PB	KR06PA	1.95 (49.5)	4.54 (115.3)	7.00 (177.8)	3/8 NPT
3/8 PCU*— Model 66 Tip	KA06PB	KSM06PB	KR06PB				

RQD | Lever Action Style for Hansen* Tips

1/4 Hansen* 2K	KA04HB	KSM04	KR04	1.75 (44.5)	4.39 (111.5)	7.00 (177.8)	1/4 NPT
3/8 Hansen* 3K	KA06HB	KSM06HB	KR06HB	1.95 (49.5)	4.54 (115.3)		3/8 NPT

Dimensions: inch (mm)



DON'T SEE A SOLUTION FOR YOUR APPLICATION? Submit a custom application form and drawing to fastsales@fastestinc.com or to your local distributor.

SNAPMATE / EXTERNAL SEALING CONNECTION TOOL

Sleeve actuated external grip and seal connection tool for CoreMax® and Schrader® flare connections.

CONNECTS TO:

45° Flare



SPECIFICATIONS

Pressure Rating	Operating Temperatures	Materials of Construction
Vacuum to 625 psi (43 bar)	-40°F to +250°F (-40°C to +121°C)	Stainless Steel, Brass
Termination Port		Seal Material*
-4 [7/16-20] 45° Flare		Neoprene®

* Additional seal material types available, consult factory.

ACTUATION METHOD

Manual Sleeve: Easy, ergonomic sleeve action eliminates repetitive twisting and turning - push to connect, pull to release

ICON™ TECHNOLOGY

Consult Factory

ACCESSORIES

Visit fastestinc.com

- 1 Internally valved for refrigerant containment upon disconnection
- 2 Collet design locks securely into CoreMax® and common Schrader® valves with 1/4 45° Flare with 7/16-20 thread
- 3 Compact size fits into tight spaces
- 4 90° termination port for best ergonomics of small connection tool
- 5 Quick and easy seal replacement to minimize down time, maintenance, and tool inventory

SNAPMATE / EXTERNAL SEALING CONNECTION TOOL

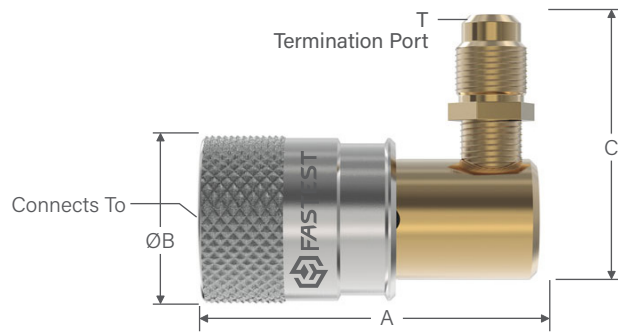

Ordering Information				Dimensions			
Connects To	Part Number	Main Seal Set	Repair Kit	A	B	C	T
CoreMax -4 [7/16-20] 45° Flare	SCTA07H	SCBA07H	SCRA07H	1.94 (49.3)	0.93 (23.6)	1.51 (38.3)	-4 [7/16-20] 45° Flare

Dimensions: inch (mm)



MBE/MRE / HVAC-R EXTERNAL SEALING CONNECTION TOOL

Sleeve actuated external grip and seal connection tools that latches over tube features.

CONNECTS TO:

Expanded CoreMax Seat

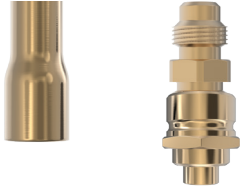

SPECIFICATIONS

Pressure Rating	Operating Temperatures	Materials of Construction
Vacuum to 625 psi (43 bar)	-40°F to +250°F (-40°C to +121°C)	Stainless Steel
Termination Port		Seal Material*
1/4 to 1-1/4 NPT		Neoprene*

* Additional seal material types available, consult factory.

ACTUATION METHOD

Manual Sleeve: Easy, ergonomic sleeve action eliminates repetitive twisting and turning - push to connect, pull to release

ICON™ TECHNOLOGY

Consult Factory

ACCESSORIES

Visit fastestinc.com

- 1 Sleeve locks under pressure to eliminate disconnection under pressure
- 2 MBE - ball latch and MRE - ring latch over tube features such as flare or bead
- 3 Straight through flow for full flow requirements
- 4 Quick and easy seal replacement to minimize down time, maintenance, and tool inventory

MBE/MRE / HVAC-R EXTERNAL SEALING CONNECTION TOOL

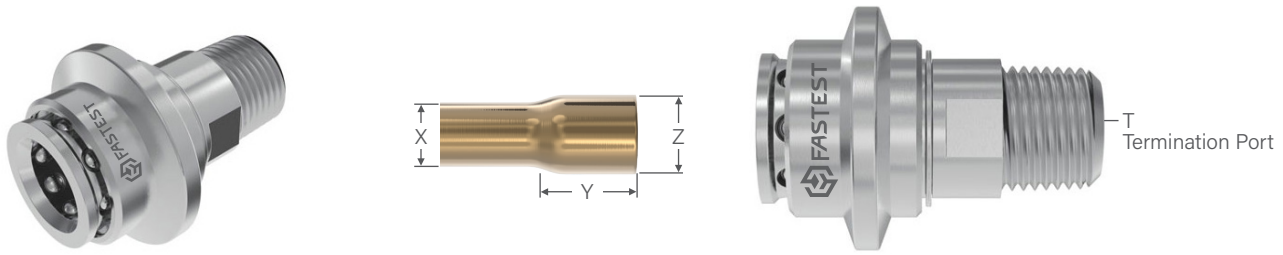

Ordering Information					Dimensions	
Connects To			Replacement Seals Pack (5)	Rebuild Kit	Termination	Flow Dia.
Tube ØX	Flare Length Y	Flare ØZ				
0.25 (6.4)	0.20 (5.1)	0.32 (8.0)	Consult Factory	Consult Factory	1/4 NPT	0.19 (4.8)
0.31 (7.9)	0.27 (6.9)	0.38 (9.7)				0.25 (6.3)
0.38 (9.7)	0.35 (8.9)	0.44 (11.3)			3/8 NPT	0.31 (7.9)
0.50 (12.7)	0.45 (11.4)	0.57 (14.5)				0.44 (11.1)
0.63 (16.0)	0.53 (13.5)	0.70 (17.8)				0.56 (14.1)
0.75 (19.1)	0.68 (17.3)	0.84 (21.3)			3/4 NPT	0.67 (16.9)
0.88 (22.4)	0.79 (20.1)	0.97 (24.6)				0.79 (19.9)
1.00 (25.4)	0.83 (21.1)	1.12 (28.5)			1 NPT	0.94 (23.9)
1.13 (28.7)	1.13 (28.7)	1.23 (31.3)			1-1/4 NPT	1.03 (26.0)
1.38 (35.1)	1.40 (35.6)	1.49 (37.9)				1.27 (32.1)

Dimensions: inch (mm)

How to Order

The MBE and MRE Series connectors are designed for mechanical gripping on expanded tubing. Connectors are designed, engineered and manufactured to your specific application requirements.

For part number and a price quotation:

- 1) Identify the gripping and sealing areas of your test piece.
- 2) Contact FasTest with information on test pressure, media and provide detailed drawing, including tolerances of test piece.



JNL / INTERNAL SEALING CONNECTION TOOL

Manual lever actuated internal grip and seal connection tool for straight tubes / bores.

CONNECTS TO:

Straight



SPECIFICATIONS

Pressure Rating*	Operating Temperatures	Materials of Construction
JNLO / JNL1: 10 mtorr (micron) to 1000 psi (68.9 bar)	-40°F to +250°F (-40°C to +121°C)	Aluminum Stainless Steel Acetal (POM) Urethane Collet Retainer
JNL2: 10 mtorr (micron) to 750 psi (51.7 bar)		
Termination Port		Seal Material**
1/8 NPT		Neoprene®

i * Pressure rating based on the test piece having a surface finish greater than 16 rms and a hardness of no more than 95 Rb to grip and seal at the rated pressure. A surface finish of 8 rms may be acceptable if the test piece has a hardness no greater than 40 Rb.

**Additional seal material types available, consult factory.

ACTUATION METHOD

Lever Actuated: Simply flip the ergonomic handle for ease of use

ICON™ TECHNOLOGY

Consult Factory

ACCESSORIES

Visit fastestinc.com

- 1** Pressure assisted sealing and gripping with internal safety lock feature prevents accidental disconnection under pressure if handle is released
- 2** Instant connection for copper, steel, and aluminum tubes commonly used in refrigeration and other industrial applications
- 3** Stainless steel collets provide maximum grip with minimum distortion of the test piece
- 4** Quick and easy seal replacement to minimize down time, maintenance and tool inventory
- 5** Self aligning connector requires no operator adjustment

JNL / INTERNAL SEALING CONNECTION TOOL

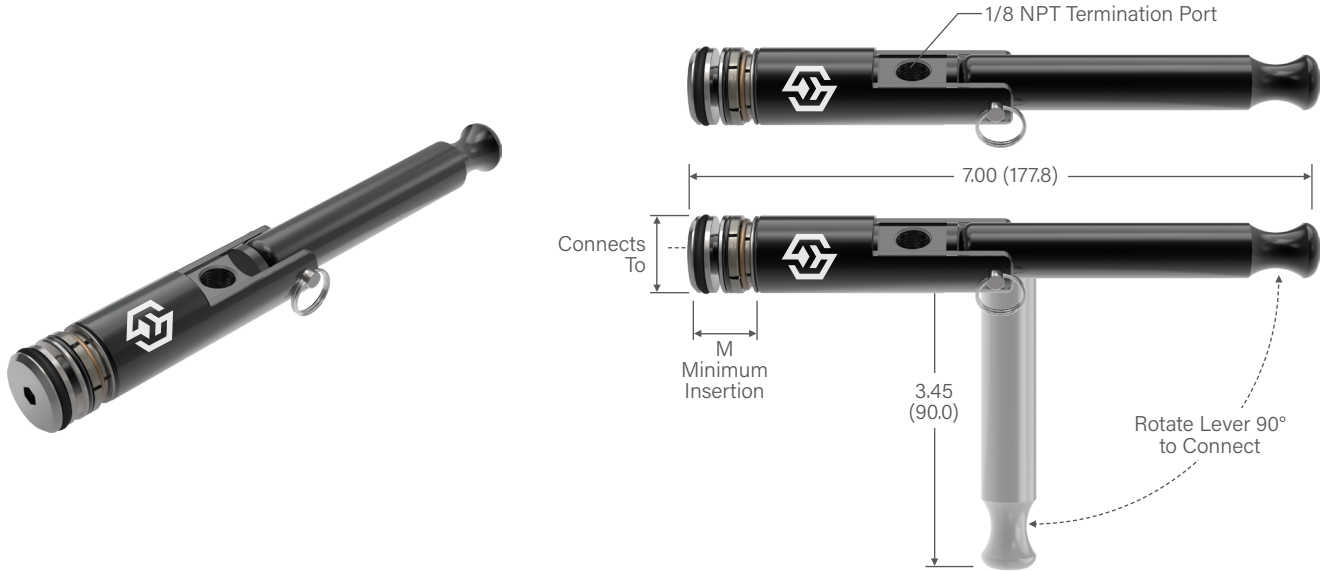

Ordering Information			Dimensions
Connects To +0.010/-0.010 (+0.25/-0.25)	Part Number	Replacement Seals Bulk Pack (5)	M

JNL0 and JNL1 | Lever Actuated Connectors for Internal Tubes / Bores

0.375 (9.5)	JNL00375H	SN00375H	0.53 (13.5)
0.500 (12.7)	JNL00500H	SN00500H	
0.590 (15.0)	JNL10590	SN10590	
0.625 (15.9)	JNL10625	SN10625	
0.750 (19.1)	JNL10750	SN10750	
0.785 (19.9)	JNL10785	SN10785	
0.875 (22.2)	JNL10875	SN10875	

JNL0 and JNL1 | Lever Actuated Connectors for Metric Internal Tubes / Bores

10mm ± 0.25mm	JNL0M10H	SN00395H	13.5 (0.53)
11mm ± 0.25mm	JNL0M11H	SN00435H	
12mm ± 0.25mm	JNL0M12H	SN00470	16.0 (0.63)
13mm ± 0.25mm	JNL0M13H	SN00515H	
14mm ± 0.25mm	JNL0M14H	SN00550H	
15mm ± 0.25mm	JNL1M15	SN10590	
16mm ± 0.25mm	JNL1M16	SN10630	
18mm ± 0.25mm	JNL1M18	SN10710	
20mm ± 0.25mm	JNL1M20	SN10785	

Dimensions: inch (mm)

NOTE: JNL sizes available in .005" (.13 mm) increments per customer request. Consult factory.



DON'T SEE A SOLUTION FOR YOUR APPLICATION? Submit a custom application form and drawing to fastsales@fastestinc.com or to your local distributor.

JNL / INTERNAL SEALING CONNECTION TOOL

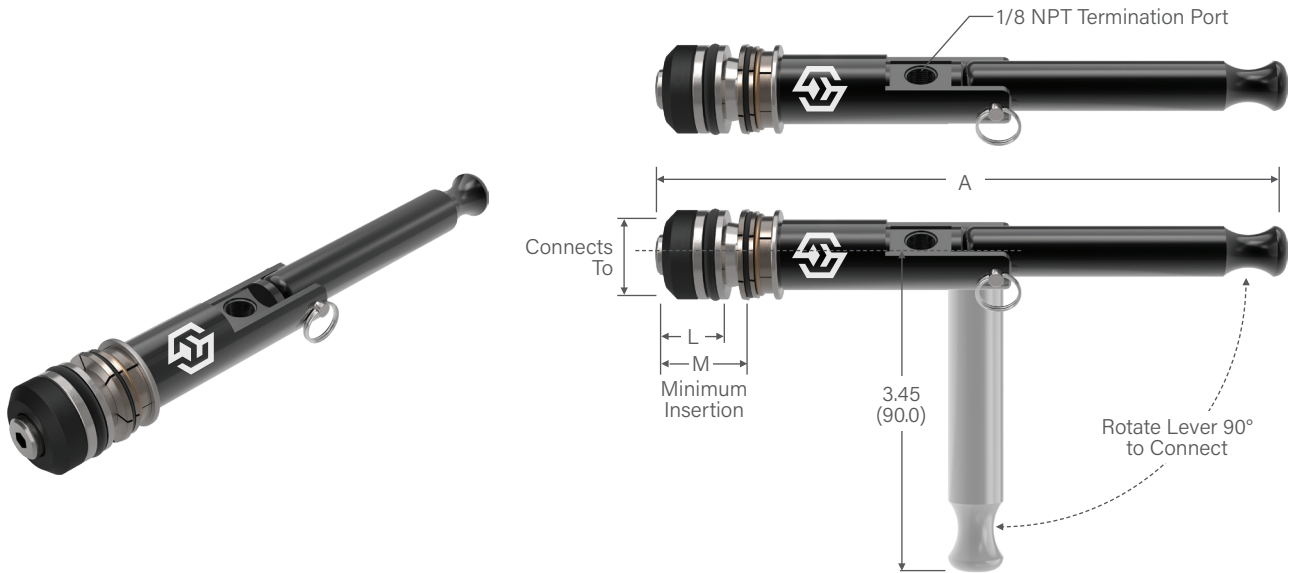

Ordering Information			Dimensions		
Connects To +0.030/-0.010 (+0.76/-0.25)	Part Number	Replacement Seals Bulk Pack (5)	A	L	M
JNL2 Lever Actuated Connectors for Internal Tubes / Bores					
1.000 (25.4)	JNL21000	SN21000	7.71 (195.8)	1.31 (33.3)	1.39 (35.4)
1.125 (28.6)	JNL21125	SN21125			
1.250 (31.8)	JNL21250	SN21250	7.71 (195.8)	1.44 (36.6)	1.51 (38.4)
1.375 (34.9)	JNL21375	SN21375	7.84 (199.1)	1.56 (39.7)	2.05 (52.1)
1.500 (38.1)	JNL21500	SN21500	7.96 (202.2)	1.69 (43.0)	2.12 (53.9)
1.625 (41.3)	JNL21625	SN21625	8.09 (205.5)	1.81 (46.0)	2.30 (58.5)

Dimensions: inch (mm)

NOTE: Additional JNL2 sizes available per customer request. Consult factory.

CUSTOM ENGINEERED SOLUTIONS



**WE TRANSFORM
STANDARDIZED
TOOLS INTO
TAILOR-MADE
SOLUTIONS TO
FIT YOUR EXACT
REQUIREMENTS.**

ASK US HOW.

JXL / EXTERNAL SEALING CONNECTION TOOL

Manual lever actuated external grip and seal connection tool for straight tube.

CONNECTS TO:

Straight Swaged



SPECIFICATIONS

Pressure Rating*	Operating Temperatures	Materials of Construction
10 mtorr (micron) to 1,000 psi (69 bar)	0°F to +200°F (-17°C to +93°C)	Anodized Aluminum, Stainless Steel, and Acetal (POM)
Termination Port		Seal Material**
1/8 to 1/4 NPT/BSPP (G)		Neoprene®

i *Pressure rating based on metal test piece not exceeding 30 Rockwell C hardness. As a general guideline, surface must be 5 micro inches or greater. Surfaces less than 5 micro inches not recommended.

**Additional seal material types available, consult factory.

ACTUATION METHOD

Lever Actuated: Simply flip the ergonomic handle in either direction for ease of use

ICON™ TECHNOLOGY

Consult Factory

ACCESSORIES

Visit fastestinc.com

- 1** Pressure assisted sealing and gripping with internal safety lock feature resists accidental disconnection under high pressure if handle is released
- 2** Instant connection for copper, steel, and aluminum tubes commonly used in refrigeration and other industrial applications
- 3** Stainless steel collets provide maximum grip with minimum distortion of the test piece
- 4** Quick and easy seal replacement to minimize down time, maintenance, and tool inventory
- 5** Self aligning connector requires no operator adjustment

JXL / EXTERNAL CONNECTION TOOL / IMPERIAL / METRIC EXTERNAL TUBES

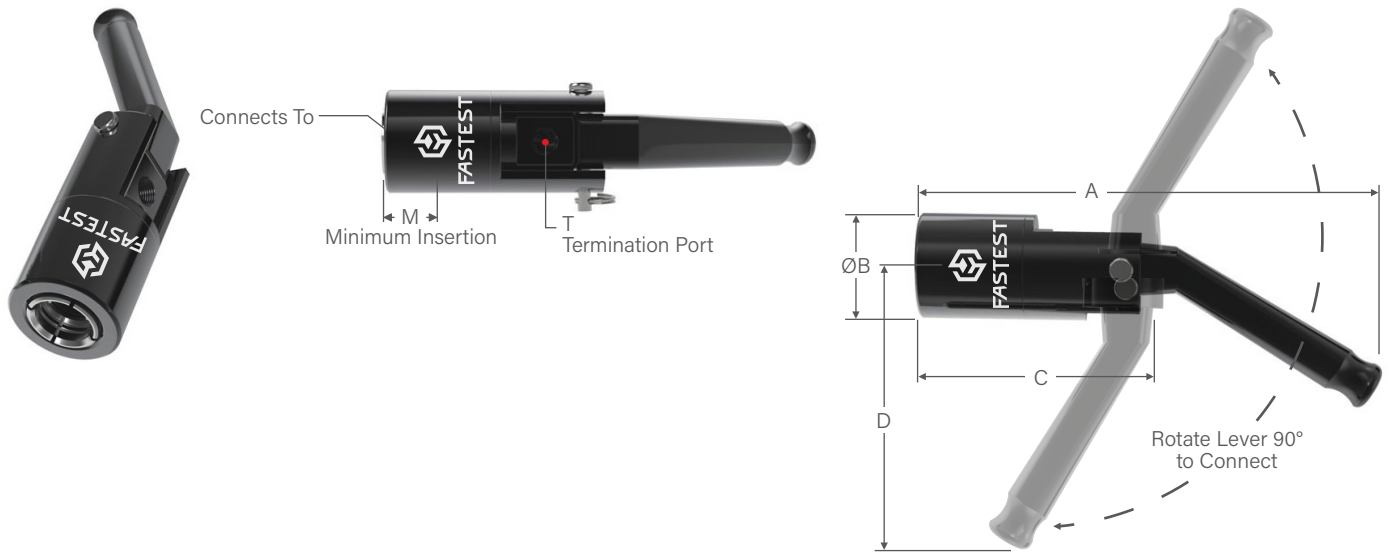

Ordering Information			Dimensions						
Sealing Range	Part Number	Main Seal Set	A	B	C	D	M	T	Flow Diameter

JXL0 and JXL1 | Lever Actuated Connectors for Imperial External Tubes

0.25 ± .010	JXL00250	SXL00250	7.27 (184.7)	1.13 (28.8)	3.65 (92.7)	4.22 (107.2)	0.79 (20.1)	1/8 NPT	0.24 (6.1)
0.312 ± .010	JXL00312	SXL00312							
0.375 ± .010	JXL00375	SXL00375							
0.500 ± .010	JXL00500	SXL00500		1.62 (41.2)	3.58 (90.9)		0.85 (21.6)	1/4 NPT	
0.625 ± .010	JXL10625	SXL10625							
0.750 ± .010	JXL10750	SXL10750							
0.875 ± .010	JXL10875	SXL10875							

JXL0 and JXL1 | Lever Actuated Connectors for Metric External Tubes

6mm ± 0.25mm	JXL0M6	SXL00236	7.27 (184.7)	1.13 (28.8)	3.65 (92.7)	4.22 (107.2)	0.79 (20.1)	1/8 BSPP (G)	0.24 (6.1)
8mm ± 0.25mm	JXL0M8	SXL00312							
10mm ± 0.25mm	JXL0M10	SXL00394							
12mm ± 0.25mm	JXL0M12	SXL00472		1.62 (41.2)	3.58 (90.9)		0.85 (21.6)	1/4 BSPP (G)	
16mm ± 0.25mm	JXL1M16	SXL10630							
18mm ± 0.25mm	JXL1M18	SXL10710							
20mm ± 0.25mm	JXL1M20	SXL10787							
22mm ± 0.25mm	JXL1M22	SXL10865							

Dimensions: inch (mm)

NOTE: Table above shows common connections. Additional sizes available for JXL Series connectors. Consult factory or details.



DON'T SEE A SOLUTION FOR YOUR APPLICATION? Submit a custom application form and drawing to fastsales@fastestinc.com or to your local distributor.

GZNV / INTERNAL GAS BURNER TESTING

Internally valved manual sealing connection tool for Natural Gas or Propane Burner Testing.

AVAILABLE RANGE: 3/8 NPT to 3/4 NPT

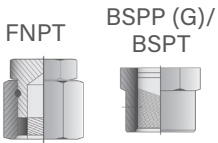

SPECIFICATIONS

Pressure Rating	Operating Temperatures	Materials of Construction
Vacuum to 5 psi (0.345 bar)	0°F to +200°F (-17°C to +93°C)	Anodized Aluminum, Brass, Molded Nylon Handle
Termination Port		Seal Material*
1/4, 1/2 NPT		Main: Urethane Internal: Buna-N

* Additional seal material types available, consult factory.

ACTUATION METHOD

Lever Handle: Two way actuation handle is simple and ergonomic for production applications

ICON™ TECHNOLOGY

Consult Factory

For part numbers or additional product information:
Contact fastsales@fastestinc.com

- 1** Lockable collar to keep sealing pressure consistent and internally valved to prevent gas flow once disconnected
- 2** Adjustable ring to accommodate the widest sealing range in the industry
- 3** Internal shut-off valve to stop the flow of gas when handle is in the disconnected position
- 4** Non-sparking aluminum and brass components

G60V / EXTERNAL GAS BURNER TESTING

Internally valved sleeve actuated external grip and seal connection tool for Natural Gas or Propane Burner Testing.

AVAILABLE RANGE: 3/8 NPT to 3/4 NPT

MNPT



SPECIFICATIONS

Pressure Rating	Operating Temperatures	Materials of Construction
Vacuum to 30 psi (2.1 bar)	0°F to +200°F (-17°C to +93°C)	Stainless Steel, Brass, Anodized Aluminum
Termination Port		Seal Material*
3/8, 1/2, 3/4 NPT		Main: Neoprene® Internal: Buna-N

* Additional seal material types available, consult factory.

ACTUATION METHOD

Manual Sleeve: Easy, ergonomic sleeve action eliminates repetitive twisting and turning - push to connect, pull to release

ICON™ TECHNOLOGY

Consult Factory

For part numbers or additional product information: Contact fastsales@fastestinc.com

- 1 SurConnect™ - Green to go visible indicator to ensure complete connection and internally valved to prevent gas flow once disconnected
- 2 Instant external threaded connection with floating piston to ensure proper face / ID sealing position
- 3 Collet design locks securely into external threads or behind the threads
- 4 Connect and seal to NPT male threads
- 5 Stainless steel components for demanding production environments - brass collets for non-sparking



DON'T SEE A SOLUTION FOR YOUR APPLICATION? Submit a custom application form and drawing to fastsales@fastestinc.com or to your local distributor.

FI / INTERNAL SEALING CONNECTION TOOL

Pneumatic sealing connection tool for internal sealing in automated and semi-automated processes.

AVAILABLE RANGE: .310" to 3.005" (7.87mm to 76.33mm)

Straight Expanded Flared Beaded Barbed Form End Swaged



NPT SAE BSPP (G)/BSPT METRIC

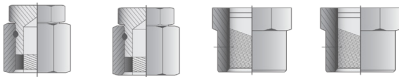

- 1 Automated processes and high-volume production testing including pick and place and delicate robotic handling applications
- 2 Capable of sealing conventional and unique sealing surfaces including smooth, porous, out of round, and threaded
- 3 Quick change seal sets to accommodate multiple sizes of tubing and easy field maintenance
- 4 Available with Shaft Extensions for accessibility to seal remote ports or multiple ports with close center to center distances - consult factory for further information

SPECIFICATIONS

Pressure Rating	Pilot Pressure	Operating Temperatures
Vacuum to 120 psi (8.3 bar)	60 to 120 psi (4.1 to 8.3 bar)	0°F to +200°F (-17°C to +93°C)
Termination Port	Materials of Construction	Seal Material*
Female 10-32 UNF, M5 x 0.8, NPT/BSPP (G): 1/8 to 3/4	Anodized Aluminum, Stainless Steel, Potted PCA	Standard: Neoprene®, Urethane Optional: FKM, Buna-N, EPDM, FDA White Neoprene®

* Additional seal material types available, consult factory.
** Operating Temp: 32°F-100°F (0°C-38°C) for ICON™.

- i** Sealing connection tool and test part should be rigidly fixtured to prevent separation when under pressure (fixturing not required for vacuum applications).

ACTUATION METHOD

Pneumatic: Pilot pressure applied to seals with no metal contact and uniform seal movement seals inside tubes and pipes with no marring.

ICON™ TECHNOLOGY

SURE SEAL™

SEAL LIFE™

For part numbers or additional product information:
Contact fastsales@fastestinc.com

FE / EXTERNAL SEALING CONNECTION TOOL

Pneumatic sealing connection tool for external sealing in automated and semi-automated processes.

AVAILABLE RANGE: .030" to 5.040" (0.76mm to 128.02mm)

Straight Expanded Flared Beaded Barbed Formed Swaged



SPECIFICATIONS

Pressure Rating	Pilot Pressure	Operating Temperatures**
Vacuum to 500 psi (34 bar)	60 psi (4.1 bar)	0°F to +200°F (-17°C to +93°C)
Termination Port	Materials of Construction	Seal Material*
Female 10-32 UNF, M5X8, NPT/BSPP (G): 1/8 to 2 1/2	Anodized Aluminum, Stainless Steel, Potted PCA	Standard: Neoprene, Urethane Optional: FKM, Buna-N, EPDM, FDA White Neoprene

* Additional seal material types available, consult factory.
** Operating Temp: 32°F-100°F (0°C-38°C) for ICON™.

i Sealing Connection Tool and test part should be rigidly fixtured to prevent separation when under pressure (fixturing not required for vacuum applications).

ACTUATION METHOD

Pneumatic: Pilot pressure applied to seals with no metal contact and uniform seal movement seals inside tubes and pipes with no marring.

ICON™ TECHNOLOGY

SURE SEAL™

SEAL LIFE™

For part numbers or additional product information:
Contact fastsales@fastestinc.com

- 1** Automated processes and high volume production testing including pick-and-place and delicate robotic handling applications
- 2** Capable of sealing conventional and unique sealing surfaces including threads with the addition of a pilot booster
- 3** Quick change seal sets to accommodate multiple sizes of tubing and easy field maintenance - use neoprene for standard sealing, use urethane for maximum abrasion resistance / high pressure and duty cycle applications

MIT / INTERNAL CONNECTIONS

Manual twist sealing connection tool for internal threaded ports.

AVAILABLE RANGE: 1/8" to 4" (3.175mm to 101.6mm) Threads

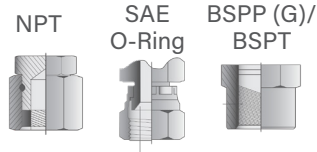

SPECIFICATIONS

Pressure Rating	Operating Temperatures	Materials of Construction
Vacuum to 10,000 psi (689 bar)	-40°F to +200°F (-40°C to +93°C)	Stainless Steel
Termination Port		Seal Material*
NPT, SAE 37° Flare		Urethane, Neoprene, or Buna-N

*Additional seal material types available, consult factory.

ACTUATION METHOD

Manual Twist: Finger-tight connection eliminates tape and sealants

ICON™ TECHNOLOGY

Consult Factory

For part numbers or additional product information:
Contact fastsales@fastestinc.com

- 1 Pressure assisted sealing eliminates leaks and resists movement under pressure
- 2 Leak-tight seal prevents contamination of media and reduces scrap and test damage
- 3 Available in flow or plug versions
- 4 Quick and easy seal replacement to minimize down time, maintenance, and tool inventory

MET / EXTERNAL SEALING CONNECTION TOOL

Manual twist sealing connection tool for external threads.

AVAILABLE RANGE: 1/8" to 3" (3.175mm to 76.2mm) Threads

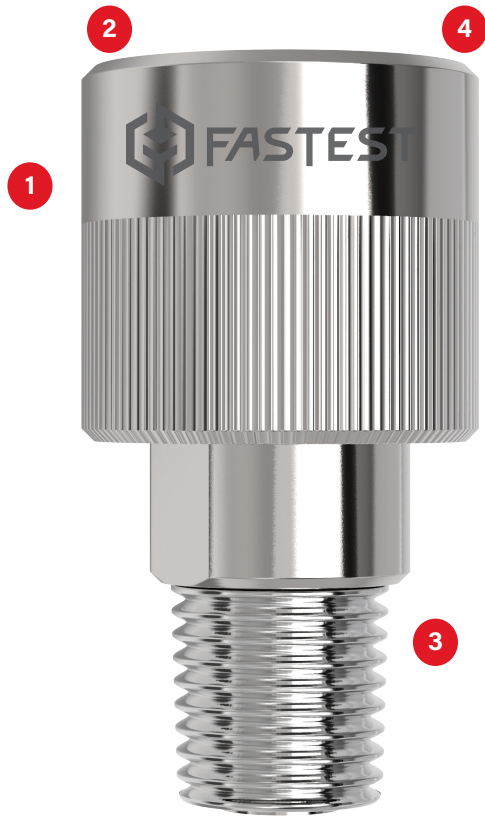
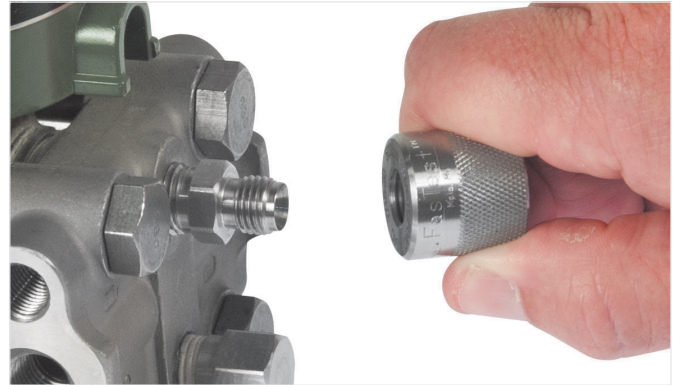

SPECIFICATIONS

Pressure Rating	Operating Temperatures	Materials of Construction
Vacuum to 10,000 psi (689 bar)	-40°F to +200°F (-40°C to +93°C)	Stainless Steel
Termination Port		Seal Material*
NPT, SAE 37° Flare		Urethane

* Additional seal material types available, consult factory.

ACTUATION METHOD

Manual Twist: Finger-tight connection eliminates tape and sealants

ICON™ TECHNOLOGY

Consult Factory

For part numbers or additional product information:
Contact fastsales@fastestinc.com

- 1 Pressure assisted sealing eliminates leaks and resists movement under pressure
- 2 Leak-tight seal prevents contamination of media and reduces scrap and test damage
- 3 Available in flow or cap versions
- 4 Quick and easy seal replacement to minimize down time, maintenance, and tool inventory

FN / INTERNAL SEALING CONNECTION TOOL

Internal thread grip and seal tool that uses threaded collets to grip threaded bores for high pressures.

AVAILABLE RANGE: 1/8" to 7/8" (3.175mm to 22.225mm) Threads

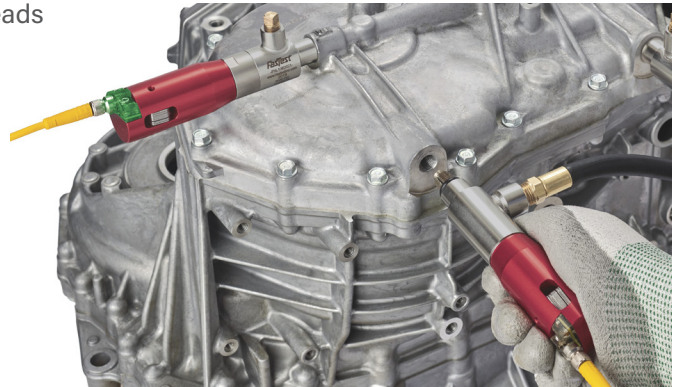
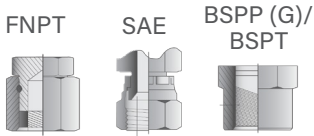

- 1** Pressure assisted grip and proprietary design locks the connector securely in the port, even when used in dynamic hydraulic applications
- 2** Instant threaded sealing connection up to 5,000 psig without tape, sealant, or wrenches - significantly reduces process time
- 3** Split collet design locks securely and will not damage threaded ports
- 4** Self aligning connector requires no operator adjustment
- 5** Quick and easy seal replacement to minimize down time, maintenance and tool inventory

SPECIFICATIONS

Pressure Rating	Operating Temperatures	Materials of Construction
Vacuum to 5000 psi (345 bar)	-40°F to +250°F (-40°C to +121°C)	Anodized Aluminum, Stainless Steel, Potted PCA
Termination Port		Seal Material*
BSPP (G) or FNPT		Buna-N

*Additional seal material types available, consult factory.
 ** Operating Temp: 32°F-100°F (0°C-38°C) for ICON™.

i Side load rating varies depending on size and insertion.

ACTUATION OPTIONS

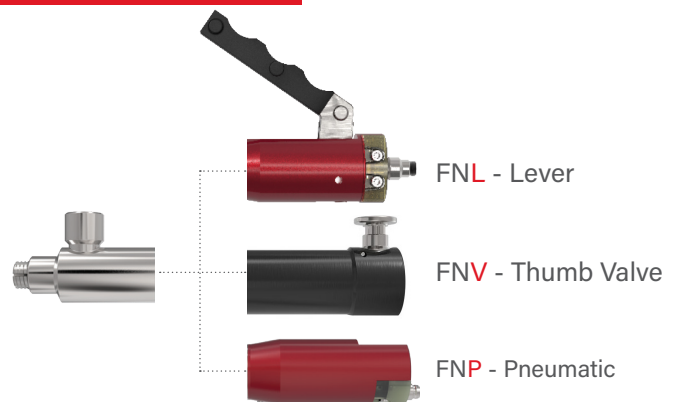

ICON™ TECHNOLOGY



For part numbers or additional product information:
 Contact fastsales@fastestinc.com



ICON™

INTELLIGENT CONNECTION TECHNOLOGY

FasTest's ICON™ adds sensing capabilities to our mechanical Sealing Connection Tools. ICON™ Tools include instant LED visual feedback and data output to improve sealing connection accuracy, maximize production efficiency, and optimize maintenance.

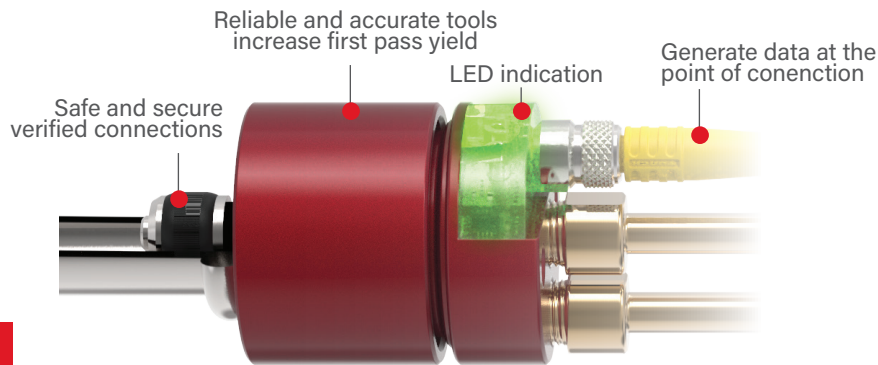

ICON™ features:



SURE SEAL™

Instant LED feedback verifies a good connection prior to starting a test.



SEAL LIFE™

Alert when the main seal is at end of life and must be replaced.

» Improve safety during functional tests.

SURE SEAL™ provides an instant LED indication of a safe and secure connection. Identify short-connects before media is introduced to prevent spills.

» Eliminate leak test false failures to improve first pass yield.

With ICON™, if the product fails a test, the connections should not be a source of leaks.

» Increase throughput and reduce downtime.

Safe, reliable, and consistent connections every cycle - test more, quicker. Reduce rework and the need to retest.

» Collect tool data.

Gather data on historical use, actuations, and cycle count to get better testing results.

» Optimize seal maintenance.

SEAL LIFE™ indicates when the main seal needs to be replaced.

Product Accessories

Charge Valve PN: ADM06102



- Use with Charge Coupler to pressure up and hold pilot charge when an affixed airline is not useable
- Manually actuate pneumatic sealing connection tools

Charge Coupler PN: ADF05102



- Used with Charge Valve to introduce pressure without latching
- Internally valved

Slide Valve PN: AV1021022



- Used to pressurize and exhaust pilot pressure for manual operation

ICON™ Accessories

Programming Tool

- Quickly program / calibrate ICON™ Sealing Connection Tools
- Eliminate the need for PLC programming
- LED connection status visual feedback
- Powered from wall adapter (included) or from a PLC (24VDC)

Part Number	Input Signal	Output Signal	Current Limit
SPCT0204	SSR	SSR	max 100 mA load
SPCT0204A	SSR	N/A	N/A

Green LED indicates good connection



M8 Cable PN: SPCAFS0602AMS06



- Straight Female M8 threaded Connector to straight Male M8 connector (6-wire 2m cable)

M8 Cable PN: SPCAFS0602C



- Straight Female M8 to Flying Leads (6-wire 2m cable)

FASTEST GLOBAL DISTRIBUTION NETWORK

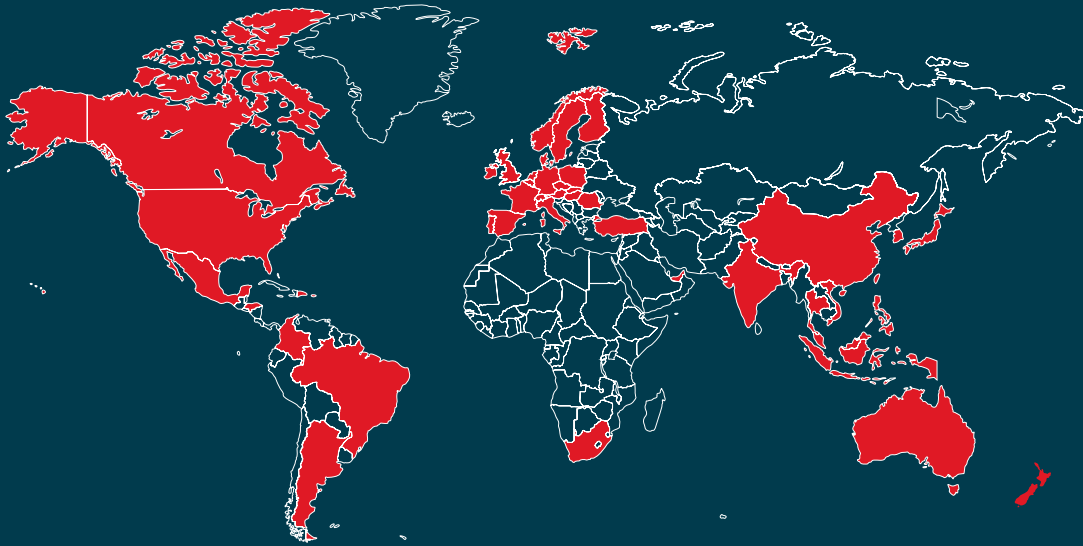

Application Experts



Quality Improvement



Standard and Customs



Intelligent Tools



FASTEST®

Designed in the U.S.A.

Headquarters | USA

1646 Terrace Drive, Roseville, MN, 55113-1317

Phone: 651.645.6266 • Fax: +1.651.645.7390 • www.fastestinc.com

Shenzhen | China

Room#1013,1015, A9 Building, Tianrui Industrial Park

No.35 Fuyuan 1st Road, FuHai residential district,

Baoan Shenzhen, China 518103

(755) 27084905 • fastsalescn@fastestusa.cn